

PRODUCT	ESPERIA 600 VANITY CARCASS (27KG)
UNIT SIZE	570w x 435d x 380h
BASIN OPT1	ABANO 600w x 460d x 60h (9KG)
BASIN OPT2	ATESSA 620w x 475d x 50h (9KG)

FITTING ADVICE

- The shaded areas indicate the clear voids for the running of services
- This unit is heavy. A secure wall fixing is required
- To aid installation, it is recommended to remove the drawers to give full access and to avoid damage.
- Recommended height from floor to top of vanity unit carcass is 810mm
- All wall to carcass and wall to basin joints should be sealed with silicone
- All dimensions are in mm

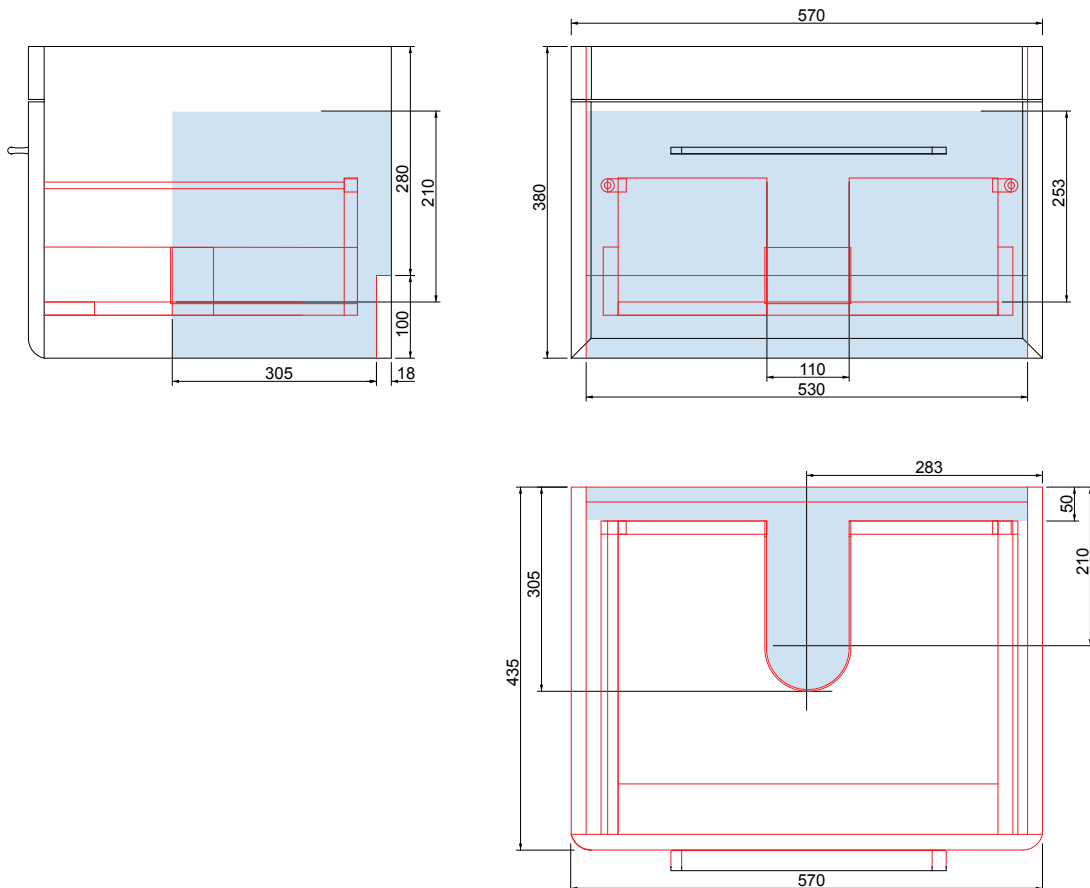

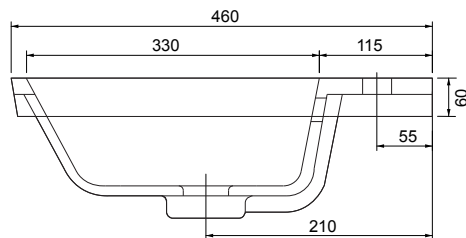
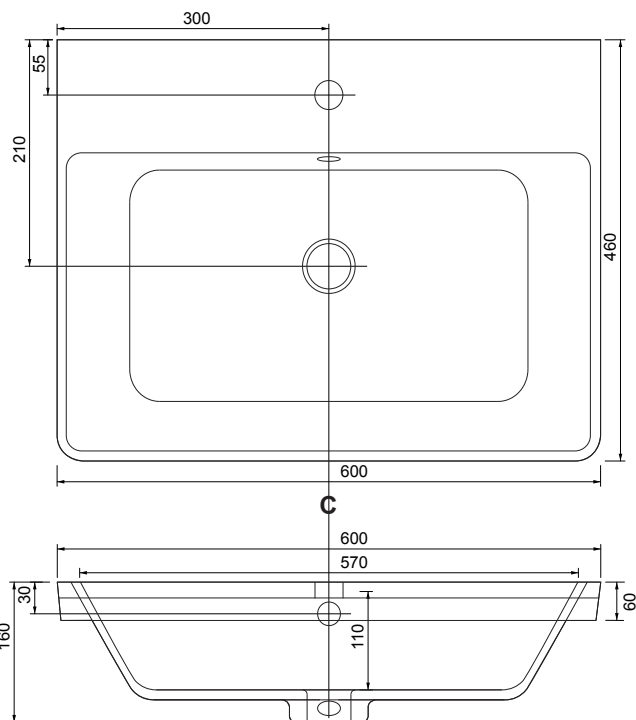

CERAMIC BASINS

Ceramic Basins are made out of liquefied fireclay which is poured into a mould and allowed to set before being hand finished. A ground glass glaze would typically be sprayed over the basin before the final firing.

This long-lasting, durable material suits a simple and minimalistic bathroom suite as well as a traditional Victorian look. Stains are easily removed and ceramic is generally easy to clean to maintain a shiny appearance. The slight ripples occasionally seen along its surface are often mistaken for flaws these are actually part of the ceramic basins characteristics.



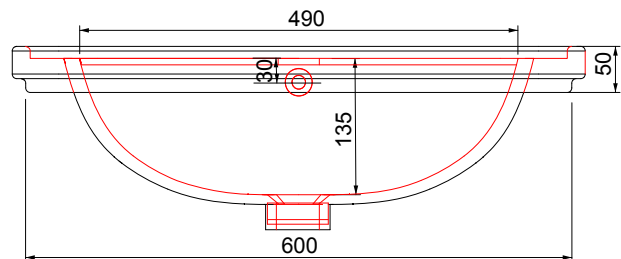
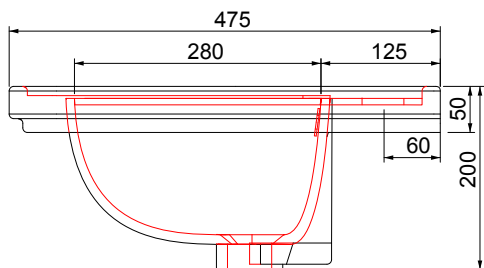
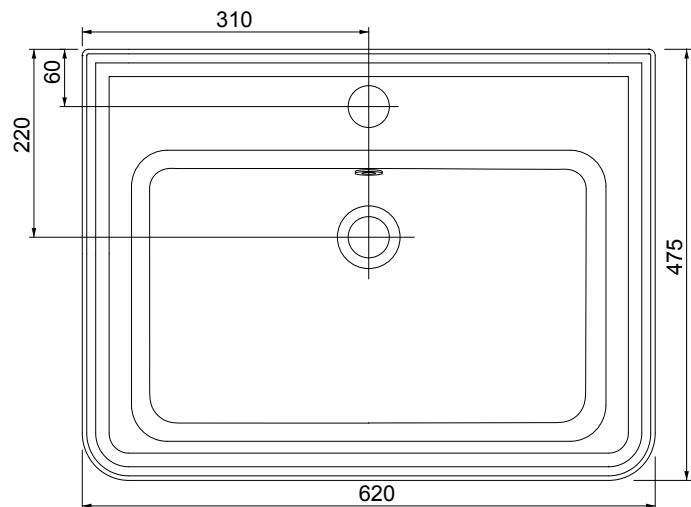

CERAMIC BASINS

Ceramic Basins are made out of liquefied fireclay which is poured into a mould and allowed to set before being hand finished. A ground glass glaze would typically be sprayed over the basin before the final firing.

This long-lasting, durable material suits a simple and minimalistic bathroom suite as well as a traditional Victorian look. Stains are easily removed and ceramic is generally easy to clean to maintain a shiny appearance. The slight ripples occasionally seen along its surface are often mistaken for flaws these are actually part of the ceramic basins characteristics.



To aid installation, it is recommended to remove the drawer to give full access and to avoid damage.

1. Fit the hanging plate to the wall using suitable fixings for the substrate.
2. Hang vanity carcass on the hanging plate and level.
3. Second fix through the rear bar locations.
4. Silicone around the top of the unit and place basin.
5. Silicone around the rear of the unit at wall abutment.
6. Re-fit drawer.

